Bio-Lynx



Introduction

Bio-LYNX is one the most advanced attendance machine packed with latest technology and updated features. It is a Wi-Fi, GPRS, GPS enabled attendance device with multiple operational modes. Perfect for attendance purpose in any condition.

Envisaged with almost every latest technology this device is designed and developed to deliver effective and efficient working under any situation. Featured with LCD display and Optical CMOS sensor, Bio-LYNX serves the purpose of attendance management effectively.

Bio-LYNX can be customized according to the requirements of the customer.



Features

- Memory Transaction: Almost unlimited records storage.
- User Capacity: Upto 15,000 (Finger + Card / Pin)
- Connectivity Modes: GPRS, Wi-Fi, Ethernet, USB, RS232.
- Data Card GSM can be used through USB port for connectivity.
- Global Positioning System(GPS) for location mapping.
- Data push technology- Client/Server Mode.
- Access Control Ready
- External Color 2MP camera (optional) for Capturing Photograph.
- Voice guided message in any English/Hindi. (Message in any other language is optional).

NOTE: Customization Possible (As per the requirement).

Specifications

Processor: 32 Bit RISC Micro Processor.

Memory Transaction: Almost unlimited records Storage in 4GB SD Memory Card

User Capacity: 15,000 (Finger + Card / Pin)

Display: LCD 128x64 STN / YELLOW Graphics Display (70.70mm × 38.80mm)

Identification Time: Less than 1 Sec

Dimension / Weight: L: 182mm H: 155mm W: 45mm / 500gms

USB Port Support: USB Pen drive for data transfer/Data Card for Connectivity.

Card Type Contact-less: EM4100 Card (Proximity) / Smart Card (ISO / IEC 14443 A)

Read Range / Frequency: EM Card up to 120mm/125KHz/MIFARE up to 60mm/13.56 MHz

Communication Method: Serial RS232, Ethernet TCP/IP, GPRS GSM/Wi-Fi

Baud Rate (Selectable): (2400-115200) bps, TCP / IP Ethernet 10/100 Mbps

Operating Temperature: 0 to 50 degree Celsius
Automatically fetches IP through DHCP (for Wireless connectivity)
Operating Humidity: 10 to 90% Non-condensing
Operating Voltage: DC 12V, 1A Through Adapter (Battery Backup Adaptor Optional)
Visual Indicator: Red / Green LED / Message on LCD in English
Audio Indicators: Voice Guided message (Adjustable volume). Voiced messages in other
Language & Customized audio greetings (Optional)

Fingerprint Scanner

Dedicated 400MHz DSP 2 Mbyte RAM
ISO/IEC 19794 Fingerprint Template
Sensor Technology: Optical CMOS
Sensing Area: 16.0mm × 19.0mm
Image Size (Pixels): 272 × 320
Image Resolution: 500 dpi
Finger Verification Option: 1:N, 1:1 (Only Finger)
Finger Template Size: 384 bytes.
EER < 0.1%
Enrollment Time: 1~1.5 Sec
Verification < 0.8 Sec
Identification Time: 1~1.5 Sec



Operational Modes

- Only finger
- Only Card
- Card with finger
- Finger in card
- Card with Password
- Pin with Password
- Only PIN



Remote Device Management

Remote Device Management allows us to manage the devices installed at multiple location with ease. Without physical manipulation, Bio-LYNX allows user to do certain things through “**web-based management module**” which eases the operation of device. Also, you can manage device location wise, dept. wise etc.

- Finger Enrolment from any location
- Addition/Deletion of USER list
- Change password of Device
- Data Deletion
- Date-Time Set
- Sending finger through server
- Multiple location device management
- 2-way communication through Dynamic IP



Data Push Technology

STAR LINK uses the “Data Push Technology” in their systems, which enables the user to collect data without any human effort. So, the systems and solutions provided by us, takes very less time to update the data. Devices automatically pushes the data as soon as any data is fed with. This helps to streamline the work-force easily, maintains the record in simpler way. It also send reports to maximum of 4 predefined recipients.



Other Utilities of Bio-LYNX



GPS for Mobile Workforce Management

When it comes to adopting new technologies into workforce management and automated tracking, STAR LINK proves itself a pioneer.



The latest and most dramatic addition to the attendance system is Global Positioning System (GPS). The GPS enabled attendance system provides real-time location with punching detail of employees. These active GPS system shows the location of the device with geographical (**longitude and latitude**) details.

Access Control with Bio-LYNX

Access Control is installed in office premises to restrict the unwanted movements.

Access Control Systems are made up of three important mechanisms: a controller, the lock and the access device.

Bio-LYNX can be used as the access device for successful operation. It also generates "**IN** and **OUT**" report for maintenance of records.



Hooter Interface with Bio-LYNX

Hooter interface is used to be connected with alarm or hooter that can be fixed through the biometric device, which is used for attendance. Bio-LYNX can be used for accurate and precise working. It is basically an interface, connected through the serial port with Bio-LYNX.



Guard Tracking with Bio-LYNX

Bio-LYNX can be used for Guard Tracking application. Guard can carry this device with them or can also be installed at certain check-points. GPS plays an active role in this application, where as Bio-LYNX is the best choice.



GPRS/Wi-Fi Connectivity

Bio-LYNX designed by STAR LINK is a GPRS/Wi-Fi enabled biometric attendance machine. It has been designed basically, keeping in mind about the problems faced by major construction companies, other security service providing agencies or for multiple location connectivity. The usage of GPRS/Wi-Fi enabled device will help to streamline the work with ease and channelize the work force.

- Reduces Wiring Cost
- Eases connectivity
- Add/Delete User List
- Allow changes in settings
- Multiple-location connectivity



Aadhar based Authentication

The management of attendance of the employees is a complex but important task, since the presence of officials directly impacts productivity and efficiency.

STAR LINK uses Bio-LYNX as one of the biometric devices in Aadhar Based Authentication process. 1:1 Authentication process with Card/PIN with finger is used to make the system more effective.

Incorporated with different functional and operational modules, this device performs proficiently in Aadhar based authentication and attendance system.

Wired Connectivity

Internal Connectivity (Ethernet)

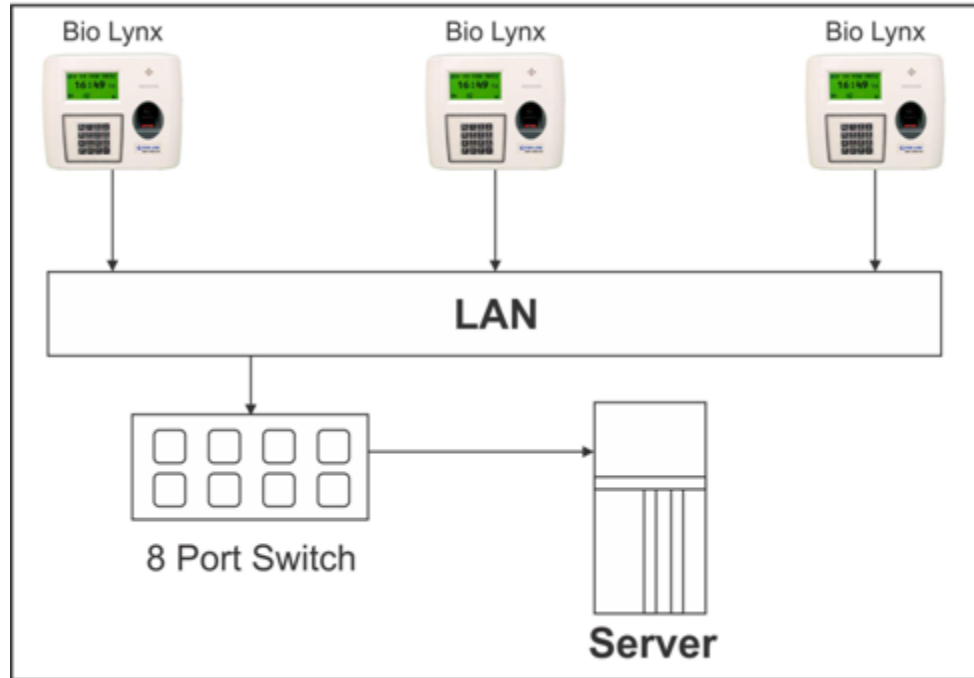

Wireless Connectivity

Wireless Connectivity (GPRS/Wifi)

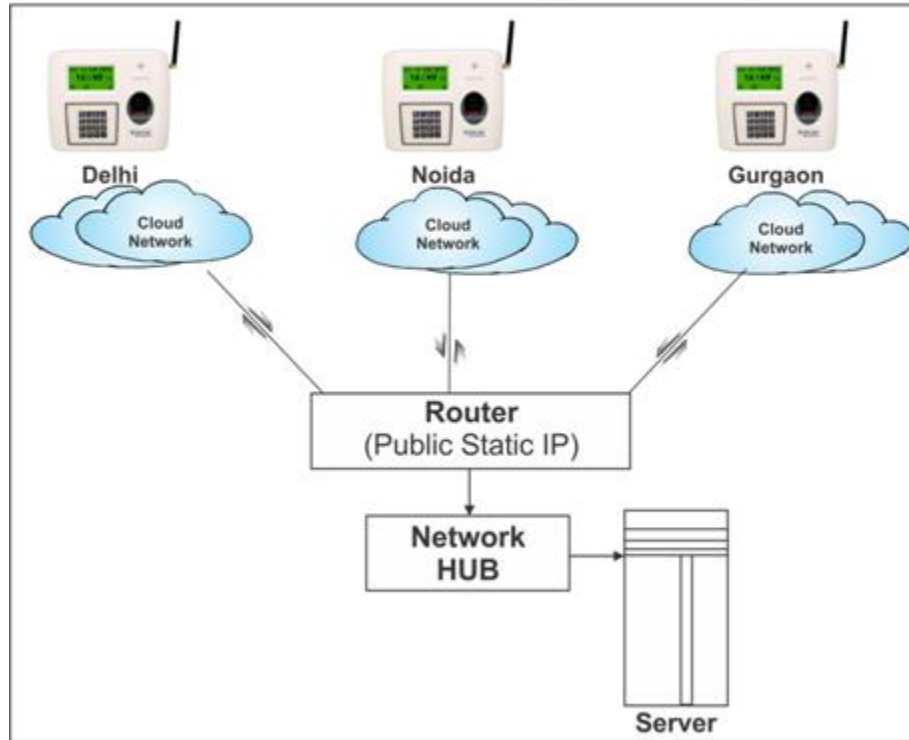

Service and Support

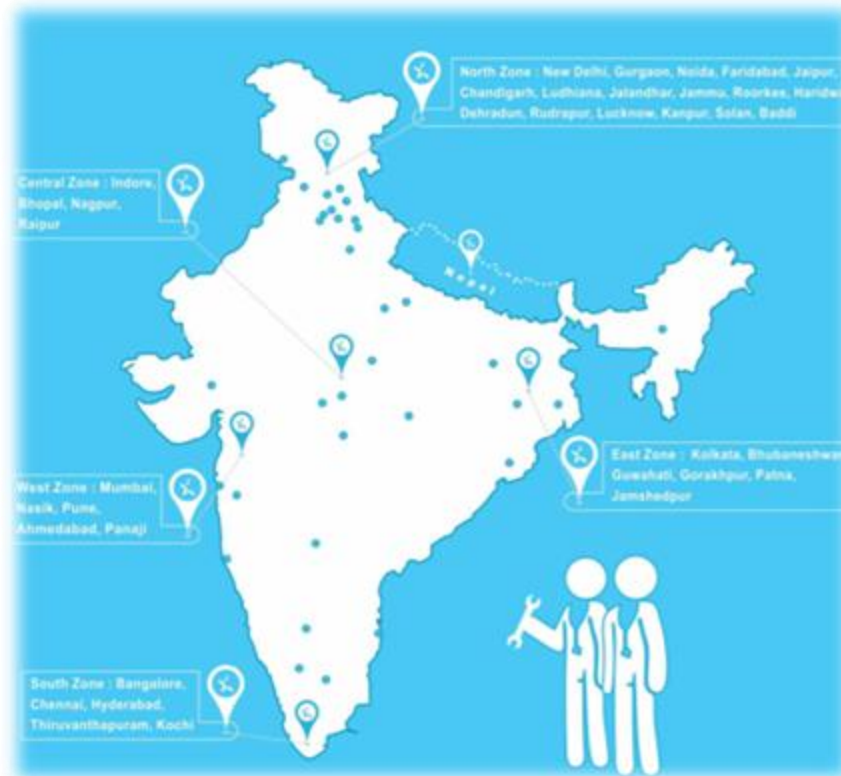

STAR LINK - Member of ESAI

STAR LINK (ISO 9001:2015) has been registered in **ELECTRONIC SECURITY ASSOCIATION OF INDIA** under leading manufacturer of Biometric Devices.



**ELECTRONIC SECURITY
ASSOCIATION OF INDIA**

ID - MA0280DL

Conclusion

In a nutshell, if you are looking to implement attendance system in your office premises, just go on for Bio-LYNX. It has been designed to serve its purpose effectively in workforce management. Equipped with every latest features and technologies, Bio-LYNX stands tall in performance and efficiency. And, the incredible service and support makes the system even more proficient in output.

For Any Biometric Needs

Contact US

Star Link Communication Pvt Ltd
D-88/4, Okhla Phase I, Okhla Industrial Area,
New Delhi-110020

Phone: 011 4059 8888(100 Lines)

Email: **sales@starlinkindia.com**

Toll Free No. **1800-11-8088**

Social Media



<https://www.facebook.com/starlinkcompvtltd/>



<http://starlinkindia.blogspot.com/>



<https://www.instagram.com/starlinkindia/>



<https://in.pinterest.com/starlinkindia/>



<https://www.linkedin.com/company/starlink-communications-pvt-ltd/>



<https://twitter.com/starlinkindia>



<https://www.youtube.com/c/StarlinkIndiabiometricsaccesscontrol>



<https://starlinkindia.hubhopper.com/>

Thank You !!!

Visit : www.starlinkindia.com